

MkIII RC MOSFET Solid State 'Nano' Switch Kit



Thank you for purchasing one of our RC Modules, we hope it will give you many years of trouble free service. If you have any problems with your module, please either email or contact our technical support helpline first on the number provided on the last page. We are sorry that it is a mobile number, but we work between three sites and find that our mobiles are far more versatile for our non – electronic communication needs.

Your MkIII 'Nano' Switch has just been made better with improved firmware and an onboard multi-function LED. This LED not only gives you an indication when the Switch is active and 'ON' or 'OFF' it detects and displays any signal errors you may have from your transmitter being switched off, signal error or if your RC Kit is incompatible with standard PWM/PPM protocols. It also gives you an assuring 3 Flash 'Greeting' to let you know all is well and ready to do some serious work.

Before pressing your switching module into service, please carefully read through the installation drawings, notes and information below.

It may well be we are 'trying to tell Grandma How To Suck Eggs' but just sometimes as we find, information is priceless knowledge, and in our case, a knowledge which we have gained over 40 years of Avionic Electronic Engineering Design and Construction experience.

Please follow the wiring protocol as in the drawing. The Conductors/Ports are clearly marked 'Load' and 'Batts' Do not connect them to anything other than what is described . 'Load' is your Lights/Pumps/Motor. 'Batts' is your Battery pack or Power Source.

Irreparable damage will occur to the internal components of the module if you:

Short Circuit The 'Load' Connections.

Cross Polarise The Supply (Battery) Connections (Positive on Negative, etc.)

Exceed the Maximum 21A Load or 30v Max supply tension

Allow water or fluid to enter the module.

Always try to use a Fuse in the 'Batt' (Supply) Line. This will help protect the Module from a possible Short Circuit or overload. It will also prevent your precious model from going up in smoke if there is such an event.  Suitable Fuses and Fuse Carriers etc. are available on our Website at www.mr-rcworld.co.uk.

Don't use the old 1/4" Glass Type Fuses and Carriers. They MELT!

In the design of this module we have tried our best to eliminate any problems which may occur during wiring installation and use, however if your miss-wire the supply or outputs, critical damage may occur.

Consequently, we appreciate that as humans we are all hard-wired to make mistakes. We too make mistakes for all sorts of reasons, and if you find you have damaged the module through a short circuit or otherwise, 'Don't Bin It!' Send it back to us and we will repair it for a very, very modest fee + return postage.

Should you need technical support for your purchase, please call +4475 9998183 (075 99998183) between 9am and 5pm Monday to Friday. Please remember, we are a Micro-Business, We DO NOT have a dedicated sales desk or enquiries/support staff consequently it may take a few attempts to speak with us. If you find this frustrating, please drop us an email with your name and a phone number and we will return your call as promptly as possible.

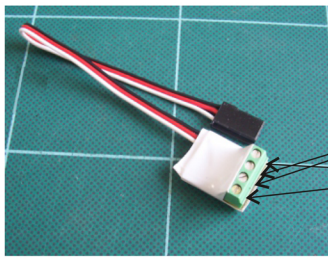

Load - Lights / Pumps etc.
Supply (Batteries)

SPECIFICATIONS
RC Receiver Voltage
Max - 11.2v

Load
Max Voltage 30v
Max Load 21A

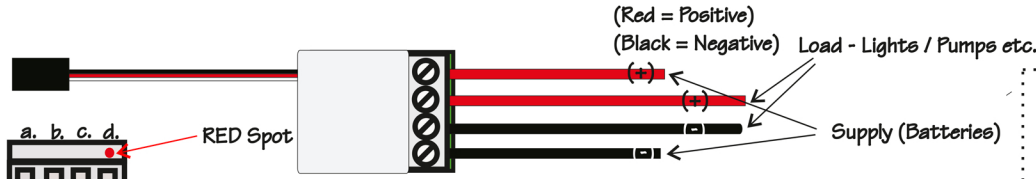
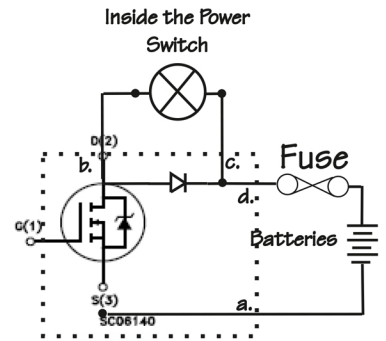

*****VERY IMPORTANT*****
Internal Damage will occur if the supply lines are cross polarised
(Positive on Negative, Negative on Positive)

**MKIII ONBOARD SIGNALLING
LEGEND**

- POWER UP INITIALISE - 3
- RAPID FLASHES
- SWITCH ACTIVE - LED ON (LIT)
- SWITCH INACTIVE - LED OFF (UNLIT)

FOR REFERENCE AND INFORMATION

If you are using LED's you MUST fit resistors into the circuit

Battery Voltage	Resistor (Ohms)
5.0V	150
6.0V	200
9.0V	360
12.0V	510

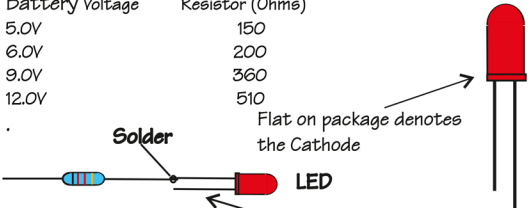

Short Leg is the Cathode.
Cathode is connected to the Negative side of the batteries

*******IMPORTANT*******

- Always fit a Fuse between your batteries and the Load.
- If there is a wiring short circuit or a defect, there is normally enough energy in your batteries to set fire to your project
- Fuses, Diodes, Resistors and Suppression Kits are available on our website at www.mr-rcworld.co.uk

Rev No	3	MR RC WORLD
May 2009		
RC Electronic Solid State		
Switch Connection Details		
MKIII (Onboard Error Signalling)		
Scale 1:1	Drawing No 1 of 2	

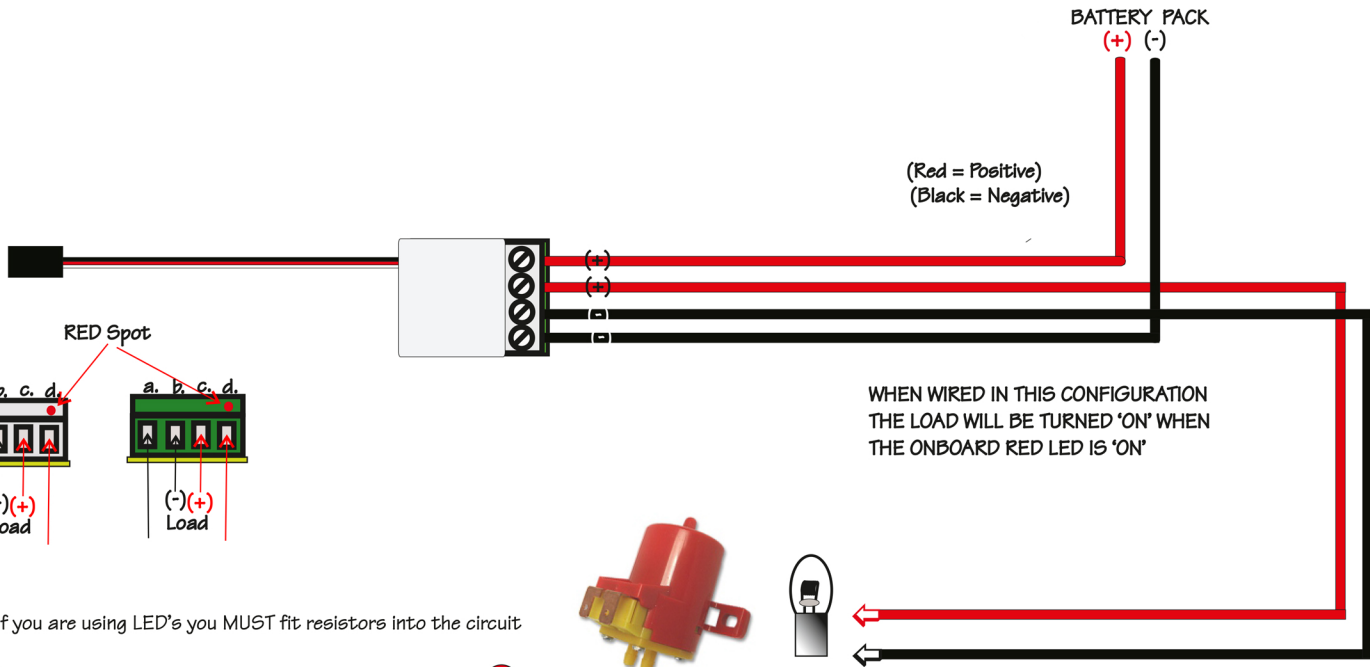

If you are using LED's you MUST fit resistors into the circuit

Battery Voltage	Resistor (Ohms)
5.0V	150
6.0V	200
9.0V	360
12.0V	510

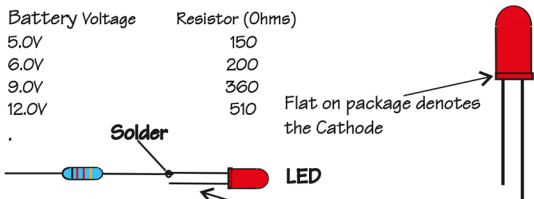

Short Leg is the Cathode.
Cathode is connected to the Negative side of the batteries

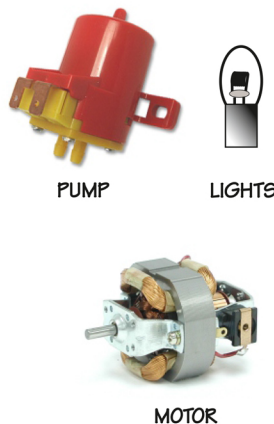

Rev No		MR RC WORLD
MAY 2009		
RC 'nano' SWITCH		
BASIC WIRING DIAGRAM		
Scale 1:1	Drawing No 2 of 2	